

METALASTIC® & PORCUPINE METALASTIC® EMI Gasketing with Pressure Seal



METALASTIC EMI Gasketing with Pressure Seal

Chomerics' METALASTIC gasketing is a composite EMI and pressure seal in thin sheet form. Shielding is provided by woven aluminum mesh, and pressure sealing is achieved by neoprene or silicone elastomer impregnated in the mesh.

METALASTIC gasketing is intended for use only in applications in which joint unevenness is less than 0.002 in. (0.05 mm), and/or where space is severely limited. The material can be cut easily into gaskets of intricate shape, and is available with a minimum nominal thickness of 0.016 in. (0.40 mm). These gaskets are not intended to be re-used after joints are opened.

METALASTIC GASKET TOLERANCES	
Dimensions	Tolerances
A 0-4.00 (0-102) over 4.00 (over 102)	±0.015 (±0.38) ±0.03 (±0.76)
B Min. Width	0.125 (3.18)
C Min. Wall Thickness	0.080 (2.03)
D Min. Diameter	0.080 (2.03)
E Slot	If min. wall thickness C cannot be accommodated, holes should be changed to slots.

Table 21

METALASTIC SHEETS			
Thickness	Width	Elastomer	Part No.
0.016 ±0.004 (0.40 ±0.10)	8.00 +0.25 -0.00 (203 +6.35 -0.00)	Silicone	04-0502
0.020 ±0.004 (0.51 ±0.10)		Neoprene	04-0202
0.020 ±0.004 (0.51 ±0.10)		Silicone	04-0102
0.020 ±0.004 (0.51 ±0.10)			

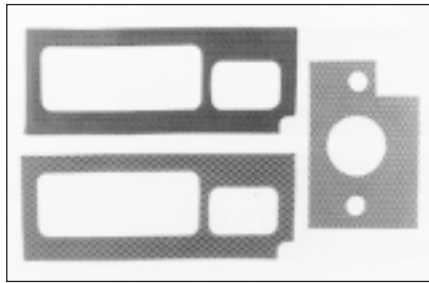

PORCUPINE METALASTIC EMI Gasketing with Pressure Seal

PORCUPINE METALASTIC is available in two forms: EMI shielding with pressure seal and EMI shielding only. Shielding is provided by severely expanded Monel foil. For composite shielding and pressure sealing, the expanded Monel is filled with a silicone elastomer.

The material gains its excellent compressibility from very uniform thickness. The expanded Monel provides dozens of contact points per square inch of surface area, assuring moderate shielding effectiveness.

PORCUPINE METALASTIC GASKET TOLERANCES	
Dimensions	Tolerances
A 0-4.00 (0-102) over 4.00 (over 102)	±0.015 (±0.38) ±0.03 (±0.76)
B Min. Width	0.140 (3.56)
C Min. Wall Thickness	0.090 (2.28)
D Min. Diameter	0.060 (1.52)
E Slot	If min. wall thickness C cannot be accommodated, holes should be changed to slots.

Table 22

PORCUPINE METALASTIC SHEETS				
Thickness	Material	Filled	Width	Part No.
0.020 ±0.004 (0.51 ±0.10)	Monel	No	12.0 ±0.25 (305 ±6.35)	08-0601
0.020 ±0.004 (0.51 ±0.10)	Monel	Yes	12.0 ±0.25 (305 ±6.35)	08-0201
0.030 ±0.004 (0.76 ±0.10)	Monel	No	12.0 ±0.25 (305 ±6.35)	08-0501
0.030 ±0.004 (0.76 ±0.10)	Monel	Yes	12.0 ±0.25 (305 ±6.35)	08-0101

PORCUPINE METALASTIC gasketing is intended for applications in which joint unevenness is less than 0.003 in. (0.08 mm) and where the gasket must be less than 4 x 6 in. (102 x 152 mm). These gaskets are not intended to be re-used after joints are opened.

Ordering Information

Sheet gasketing: Order by part number from Table 21 or 22. All METALASTIC sheets are 8.0 in. wide (20.32 cm), and PORCUPINE METALASTIC sheets are 12 in. (30.4 cm) wide. Both are supplied in continuous lengths.

Custom die-cut gaskets: Specify material from the table by part number and submit a drawing. For gaskets exceeding standard width, a miter or dovetail joint is recommended.

For additional assistance, contact Chomerics' Applications Engineering Department.

Dimensions for METALASTIC and PORCUPINE METALASTIC Die-Cut Gaskets

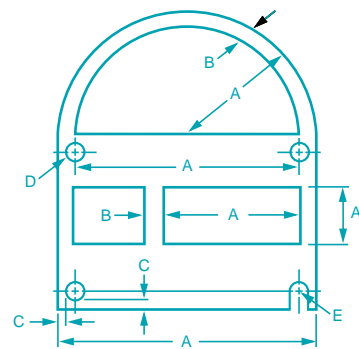

(For tolerances, see tables at left.)

(mm dimensions in parentheses)