

ZIP-EX-2® Cable Shielding

ZIP-EX-2 Cable Shielding

ZIP-EX-2 cable shielding provides convenient, inexpensive EMI and EMP shielding of cable harnesses for computers, communications equipment and other interference-sensitive electronic systems. It can be opened and closed quickly, before or after the cable is installed.

The shielding medium is 4 ply 2 strand 0.0045" wire diameter Ferrex® knitted wire mesh with the option of a Black Vinyl or Fire Retardant/Anti-Static PE protective covering, a combination that provides flexibility and durability as well as positive shielding.

A conductive Velcro® fastening system provides continuous closure. It consists of nylon hook & loop tapes impregnated with silver. This system also allows ease of opening and closing.

Configurations

ZIP-EX-2 shielding is supplied in nine diameters ranging from 1 to 6 inches (2.54 to 15.4 cm).

Straight lengths up to 50 feet (15.4 m) are available, as well as transition components ("Y" and reducer) and bulkhead terminations. Transition components may be specified with two diameters, A and B, (see Figure 2). Diameter A is always the larger of the two.

All ZIP-EX-2 should be terminated to optimize shielding. A bulkhead termination typically consists of hose clamping the ZIP-EX-2 sleeve around the collar of the bulkhead and bolting the flange to the mounting surface. A split bulkhead is another option where the bulkhead is supplied in two equal halves and can be retro-fitted around cables already in place. Dimensions for these terminations can be found on the next page. For non-standard dimensions, please contact our Applications Engineering Department.



Ordering Information

Complete descriptive part numbers should be developed in accordance with the instructions that follow. *Important Note:* To specify diameter in the part number, indicate in the appropriate place the total number of 0.250 in. (6.35 mm) increments in the diameter, not the actual diameter (see Table 1).

Part numbers for *split couplers* and *terminations* are given in Tables 3 and 4.

Part numbers for *straight lengths*, *Y transitions* and *reducers* are established as follows:

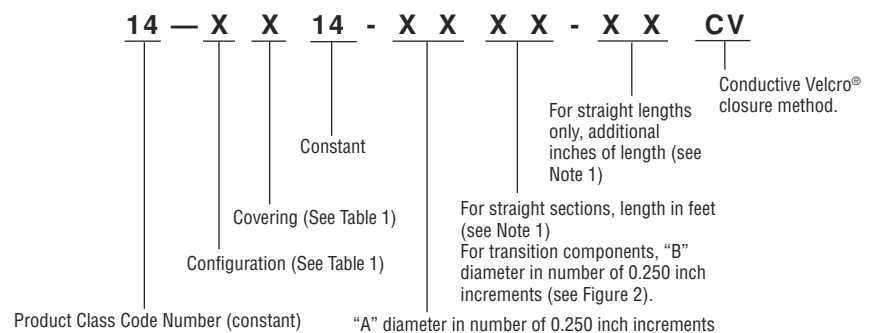

Note 1: Lengths must be shown as the number of complete feet and the number of additional inches. **Wrong:** 52 inches. **Right:** 4 feet 4 inches with the last four digits reading **-04-04**. Metric dimensions must be converted to feet and inches.

Table 1

Configuration	Covering
1 straight length	1 black vinyl
2 reducer	2 Fire Resistant/Anti-Static PE
5 Y	
Diameters A and B	
Indicate total number of 0.250 inch increments for each diameter. (Metric values must be converted.)	
Example	
For 1 inch (25.4 mm) dia., use 04	
See Tables 6, 7 and 8 for details on the covering options and conductive velcro.	

Sample Part Numbers

14-1114-0432-06CV — A straight length with black vinyl covering, 1.0 inch (25.4mm) dia., 32 ft. 6 inches (9.9m) in length.

14-2114-1208CV — A reducer with black vinyl covering, reducing from 3.0 inch (76.2mm) dia. to 2.0 inch (50.8mm) dia.

14-1214-1438-00CV — A straight length with Fire Resistant/Anti-Static PE covering, 1.5 inch (38.1mm) dia., 38 ft. (11.6m) in length.

14-5114-1410CV — A Y-Transition with black vinyl covering, transitioning from 3.5 inch (88.9mm) dia. to 2.5 inch (63.5mm).

Table 2

STRAIGHT LENGTHS <i>inch (mm)</i>		
Nominal I.D.	Contained Diameter	Part Number Base
1.0 (25.40)	0 to 0.75 (0 to 19.05)	14-1X14-04XX-XXCV
1.5 (38.10)	0.50 to 1.25 (12.70 to 31.75)	14-1X14-06XX-XXCV
2.0 (50.80)	1.00 to 1.75 (25.40 to 44.45)	14-1X14-08XX-XXCV
2.5 (63.50)	1.50 to 2.25 (38.10 to 57.15)	14-1X14-10XX-XXCV
3.0 (76.20)	2.00 to 2.75 (50.80 to 69.85)	14-1X14-12XX-XXCV
3.5 (88.90)	2.50 to 3.25 (63.50 to 82.55)	14-1X14-14XX-XXCV
4.0 (101.60)	3.00 to 3.75 (76.20 to 95.25)	14-1X14-16XX-XXCV
5.0 (127.00)	3.50 to 4.75 (88.90 to 120.65)	14-1X14-20XX-XXCV
6.0 (152.40)	4.50 to 5.75 (114.30 to 146.05)	14-1X14-24XX-XXCV

Figure 1

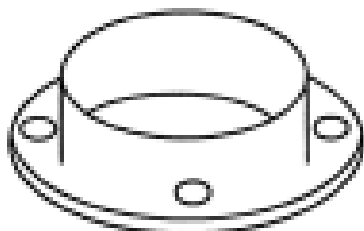

BULKHEAD TERMINATION

- SAE 1018 Steel
- Tin Plate per ASTM B-545, Class C
- A Chomerics COMBO® GASKET around the perimeter of the flange provides an environmental seal and shielding (for both standard and split.)

Table 3

BULKHEAD TERMINATIONS	
Standard Bulkhead	Split Bulkhead
15-6004-0001	15-6004-0002
15-6006-0001	15-6006-0002
15-6008-0001	15-6008-0002
15-6010-0001	15-6010-0002
15-6012-0001	15-6012-0002
15-6014-0001	15-6014-0002
15-6016-0001	15-6016-0002
15-6020-0001	15-6020-0002
15-6024-0001	15-6024-0002

[Click here for dimensional details](#)

Figure 2

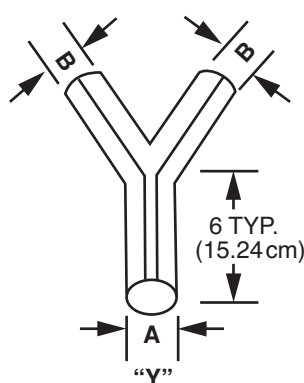

"Y" TRANSITION

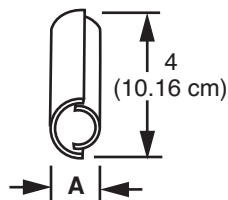

SPLIT COUPLER

- SAE 1018 Steel 16 Gauge
- Tin Plate per ASTM B-545, Class C

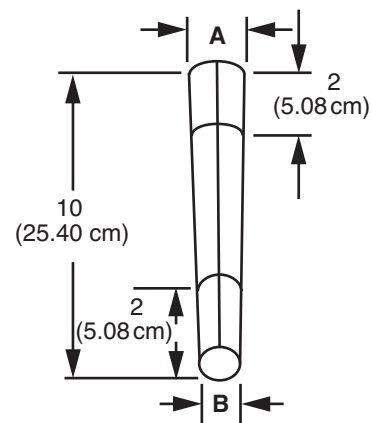

REDUCER

Table 3

TRANSITION COMPONENTS <i>inch (mm)</i>			
Nominal I.D. (A)	Y Transitions	Reducers	Split Coupler
1.0 (25.40)	14-5114-04XXCV	—	15-6004-0005
1.5 (38.10)	14-5114-06XXCV	14-2114-06XX	15-6006-0005
2.0 (50.80)	14-5114-08XXCV	14-2114-08XX	15-6008-0005
2.5 (63.50)	14-5114-10XXCV	14-2114-10XX	15-6010-0005
3.0 (76.20)	14-5114-12XXCV	14-2114-12XX	15-6012-0005
3.5 (88.90)	14-5114-14XXCV	14-2114-14XX	15-6014-0005
4.0 (101.60)	14-5114-16XXCV	14-2114-16XX	15-6016-0005
5.0 (127.00)	14-5114-20XXCV	14-2114-20XX	15-6020-0005
6.0 (152.40)	14-5114-24XXCV	14-2114-24XX	15-6024-0005

Table 4

CODE XX IN TABLE 3	
Diameter B	Code XX
1.0 (25.40)	04
1.5 (38.10)	06
2.0 (50.80)	08
2.5 (63.50)	10
3.0 (76.20)	12
3.5 (88.90)	14
4.0 (101.60)	16
5.0 (127.00)	20
6.0 (152.40)	24

Table 5

TYPICAL PHYSICAL PROPERTIES OF COMMERCIAL VINYL		
Property	Standard Value	Test Method
Thickness (inches)	0.020	ASTM D-751
Embossing	Plain	—
Color	Black	—
Weight (oz./sq.yrd.)	17.5 min.	ASTM D-751
Volatility (% loss)	1.5 max.	ASTM D-1203-86, Method B
Elongation (%)	MD* 350 min.	ASTM D-882
	TD** 360 min.	
Elongation Change After 14 Days x 150°F	MD Less than 10%	ASTM D-882
	TD Less than 10%	
Breaking Strength Factor (psi)	MD 44	ASTM D-882
	CD*** 44	
Tensile Change After 14 Days x 150°F	MD Less than 10%	ASTM D-882
	CD Less than 10%	
Graves Tear (lbs)	5.6 min.	ASTM D-1004
Low Temperature (°F)	-20 min.	ASTM-1790
High Temperature	173 max.	—
Dimensional Stability (%)	-5 max.	ASTM D-1204
Specific Gravity	1.22	ASTM D-792
Mildew Resistance	Passes ATCC No. 6275	Bureau of Home Furnishings & Thermal Insulation, Technical Bulletin 128
Bacteria Resistance	Passes ATCC No.6538, 4352	Bureau of Home Furnishings & Thermal Insulation, Technical Bulletin 128
Hydrostatic Resistance (psi)	75	ASTM D-751
Puncture Resistance (lbs)	34.3	Bureau of Home Furnishings & Thermal Insulation, Technical Bulletin 100
*MD: Machine Direction **TD: Transverse Direction ***CD: Cross-Machine Direction		

Table 6

TYPICAL PHYSICAL PROPERTIES OF THE CONDUCTIVE VELCRO	
Property	Standard Value
Wheel Cycle Life in Peel Mode (Cycles)	10,000 max.
Shear Strength Lengthwise (PSI Average)	11.0
Curved Shear on 1/2" Radius (PSI Average)	22.0
Tension or Latching Effect (PSI Average)	4.0
Peel Strength Lengthwise (PSI Average)	1.0
Temperature Range Based Upon 1000 Hours of Exposure (°F)	360 High -70 Low
Available Widths (inches)	1
Available Colors	Gray
*The conductive Velcro consists of Nylon Hook & Loop Tapes impregnated with silver.	

Table 7

FIRE RETARDANT/ANTI-STATIC COVERING DETAILS
Passes NFPA 701-99 Test 1 FR Standard
Passes ASTM E-84 Class A, with Flame Spread Value 15 and Smoked Developed Value 0
Passes Surface Resisivity, AMSI/ESD-S11.11, 10 ¹² max.ohms/sq.
Durable 0.006" thick Polyethylene
Provides fire retardant protection for any surface
Dust and Dirt do not cling to the surface as with most plastic sheeting
Color: Off-White

NOTE: All Specifications Current as of 7/25/09, Rev.2